

Product Details

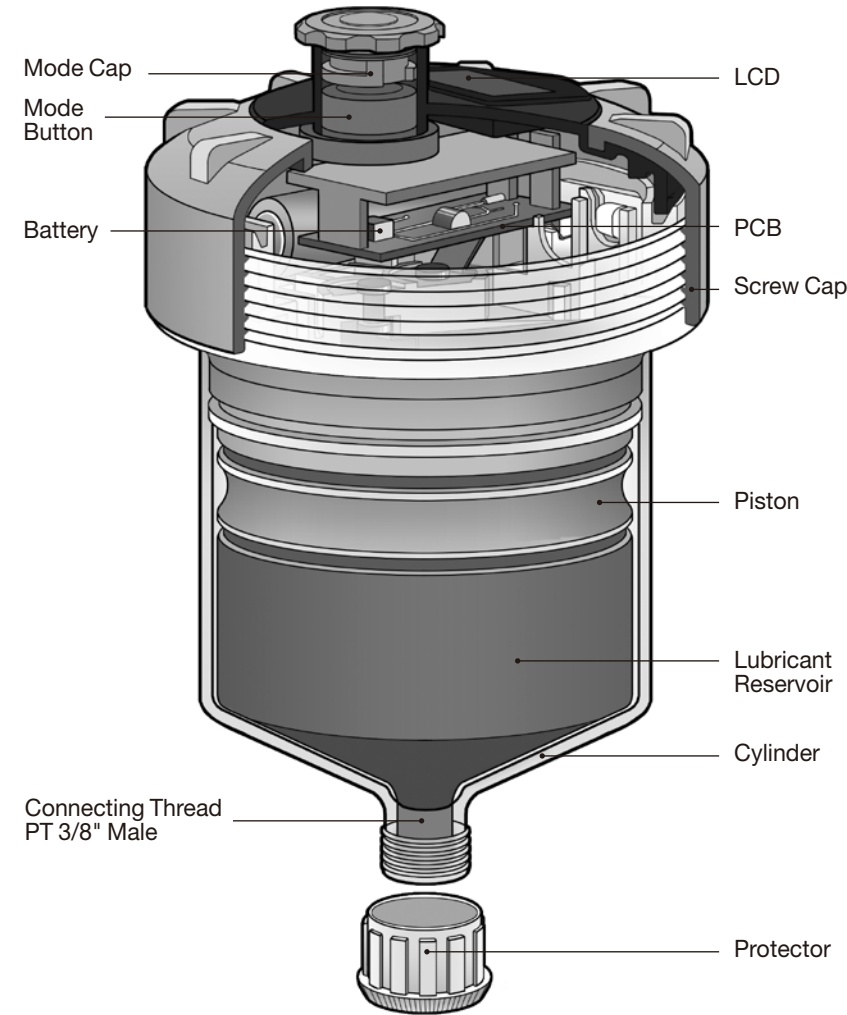

Installation/Disposal Guidelines

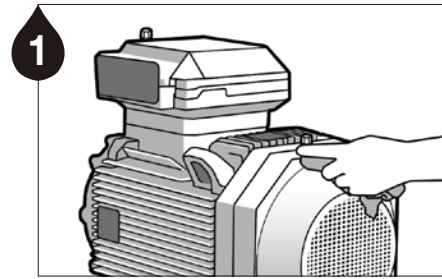

1 Remove contaminants around the lube point.

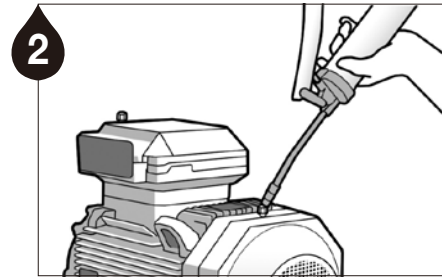

2 Ensure a clear passage using a manual grease gun. **Note1** Remove any hardened grease by purging the lube point with a manual grease gun. **Note2** The grease in the equipment and the grease contained in the unit should be the same or compatible.

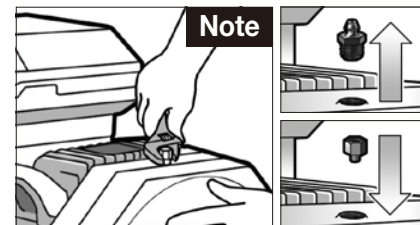

Note Remove the grease nipple and install appropriate adaptors.

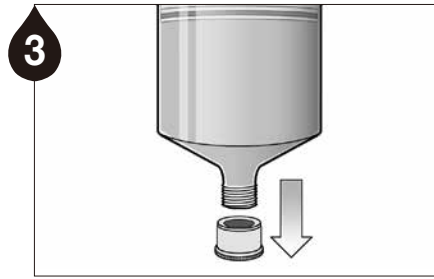

3 Remove the protector.

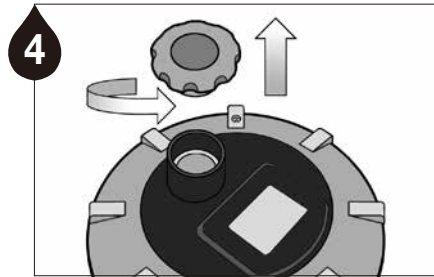

4 Turn the mode cap counterclockwise and unscrew the cap.

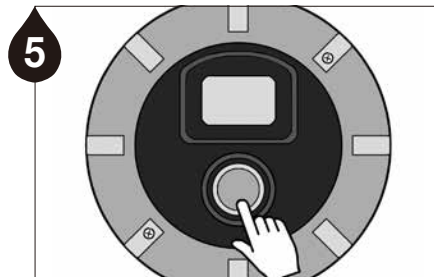

5 Press the MODE button firmly to activate the unit.

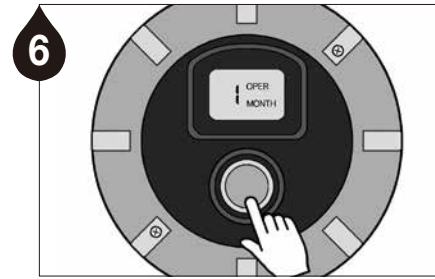

6 Select the dispensing period by pressing the MODE button.

LCD Display

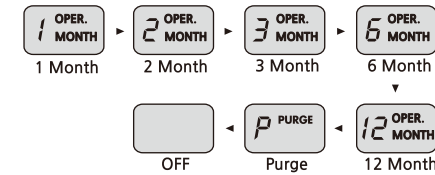

Note Each single press of the button advances to the next setting as follows.

Purge Mode

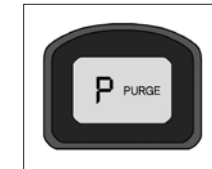

Purge mode dispenses a large quantity of grease in less than an hour. After the Purge mode is used, reset the unit to the desired dispensing period for further use.

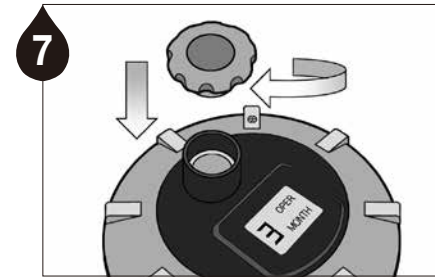

7 Once the dispensing period is set, screw the mode cap back on.



8 Log the installation date and the scheduled date of lube cycle completion on the label of the Pulsarlube V.

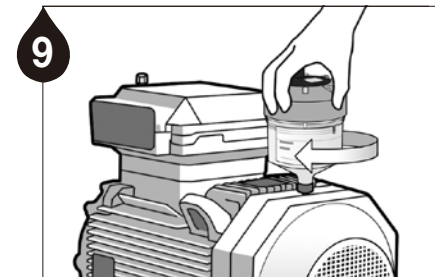

9 Install the Pulsarlube V unit on the lube point.

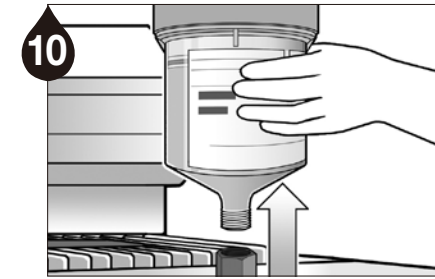

10 When the selected dispensing period of the Pulsarlube V has completed, remove the lubricator from the application.

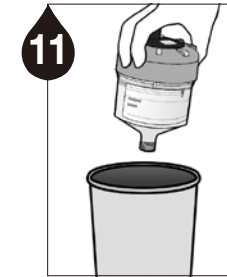

This product is a disposable unit. Dispose of remaining plastic components complying with local regulations for recycling.

Warning Do not cut, puncture, or reuse lubricator. Do not change or recharge the battery.



12 To avoid any potential injury or hazard, do not tamper with the product.

Mounting Installations

High backpressure can cause a delay in dispensing (must be under 5 bar).

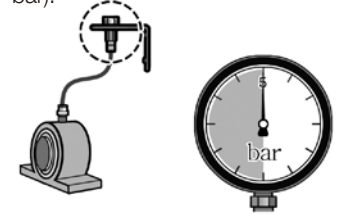

If the product is installed at a 45° or 90° angle, please use an angle adapter with a diameter greater than or equal to 1/4".

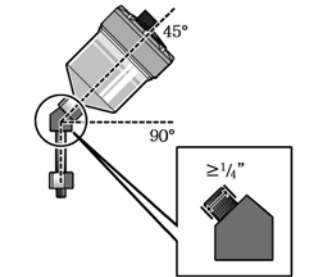

For remote installation using an Ø8 O.D. tubing, keep the maximum distance at 1m (3ft) or less.

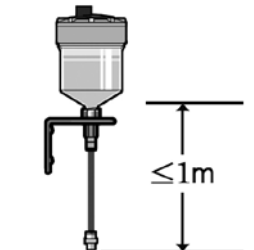

Pulsarlube V Standard Lubricants

Grease	Grease Type	Description
PL1	Multi Purpose	High performance multipurpose lubricant
PL2	Heavy Duty	Excellent extreme pressure lubricant containing solid lubricants
PL3	High Speed	Superior high speed (over 3,000 rpm) or high DN lubricant
PL4	H1 Food Grade	NSF H1 registered food grade lubricant
PL5	High Temperature	High oxidation stability lubricant
PL6	Multi Purpose with MoS ₂	Multipurpose lubricant fortified with extreme pressure additives and MoS ₂
PL7	Low Temperature	Synthetic lubricant for extreme low temp applications (below 15°C)
PL10	Electric Motor Bearing	High vibration-resistance lubricant

Dispensing Recommendations

Below are some general guidelines for bearing lubrication requirements. Requirements may vary with individual bearing types and operating conditions. Testing is recommended for specific applications. Please contact your distributor should you need any assistance in setting proper dispensing rates.

Ball & Roller Bearings

Bearing Shaft Diameter	125ml	Dispensing Volume	250ml	Dispensing Volume
121mm~305mm	–	–	–	–
105mm~120mm	–	–	1 month	8.3ml/day
89mm~104mm	1 month	4.2ml/day	2 month	4.2ml/day
80mm~88mm	2 month	2.1ml/day	3 month	2.8ml/day
64mm~79mm	3 month	1.4ml/day	6 month	1.4ml/day
51mm~63mm	6 month	0.7ml/day	12 month	0.7ml/day
25mm~50mm	12 month	0.3ml/day	–	–

Note Dispensing volumes (ml/day) are calculated assuming the lubricator is operating at 1 atm (14.7psi), 20°C. Output volume may vary with ambient temperature changes, atmospheric pressure changes, consistency of lubricant, or any resistance or backpressure existing at the lube point (bearing or passage).

Warning This product is a disposable unit. Please replace with a new unit once set dispensing period has completed.

Product Certifications

Certifications		
IECEX	Ex ia IIC T4 Ga IECEX KTL 10.0004X -20°C ≤ Ta ≤ +55°C	IEC 60079-0 : 2011 IEC 60079-11 : 2011
ATEX	CE 0344 II 1 G Ex ia IIC T4 Ga KEMA 10ATEX0150 X -20°C ≤ Ta ≤ +55°C	EN 60079-0 : 2012 + A11 : 2013 EN 60079-11 : 2012
KCs	Ex ia IIC T4 10 - KB2BO - 0226X -20°C ≤ Ta ≤ +55°C	IP68
UL	UL US LISTED E352761	Lubricant Dispenser for Use in Cl. I, Div. 1, Gps. A, B, C and D hazardous locations, intrinsically safe, Exia, Temp. Code T4, -20°C ≤ Ta ≤ +55°C

Approval No. 18-A180003-0
TESTED FOR INTRINSIC SAFETY IN METHANE
-AIR MIXTURES ONLY

Warning The batteries are not user-replaceable

Mounting Methods

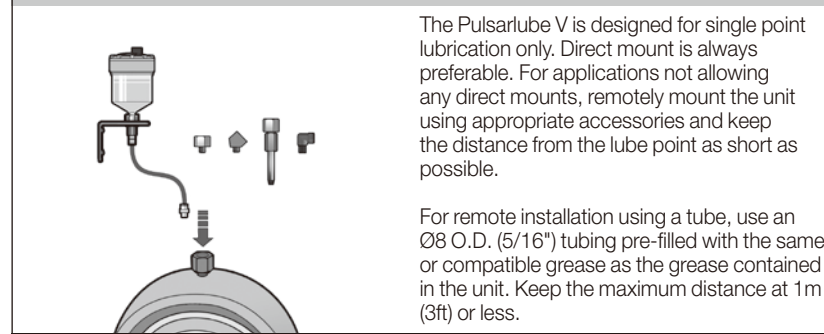

The Pulsarlube V is designed for single point lubrication only. Direct mount is always preferable. For applications not allowing any direct mounts, remotely mount the unit using appropriate accessories and keep the distance from the lube point as short as possible.

For remote installation using a tube, use an Ø8 O.D. (5/16") tubing pre-filled with the same or compatible grease as the grease contained in the unit. Keep the maximum distance at 1m (3ft) or less.

Warning If possible, please avoid using remote installation when the unit is set at the 12 month dispensing period due to low pressure.

Shelf life and Product Warranty The shelf life of the Pulsarlube V unit is 1 year from the date of production. Product warranty is limited to original defects in material and workmanship and will not cover any collateral damage due to mishandling, abuse and/or any other inappropriate use of this product. Warranty period is 1 year from the date of purchase.

Rev.03

PULSARLUBE
The World Leader of Automatic Lubrication

Pulsarlube USA, Inc.
1480 Howard Street, Elk Grove Village, IL 60007, USA
TEL:1-847-593-5300 FAX:1-847-593-5303 www.pulsarlube.com / info@pulsarlube.com

